

Rotating Anode X-Ray Tube Housing Assembly

- ◆ High speed rotating anode X-ray tube housing assembly for high energy radiographic and cine-fluoroscopic operations.
- ◆ The heavy anode is constructed with specially processed rhenium-tungsten faced molybdenum target which has an improved coating to increase thermal emissivity.
- ◆ This tube has foci 1.2 mm and 0.6 mm, and is available for a maximum tube voltage 150 kV with Single-phase or Three-phase generator.
- ◆ Accommodated with IEC 60526 type high-voltage cable receptacles.

General Data

IEC Classification Class I

Electrical:

Circuit (Center-grounded) Single-phase full-wave rectified
or Three-phase full-wave rectified

Operating Tube Voltage:

Radiographic 40 ~ 150 kV Max.

Fluoroscopic 40 ~ 125 kV Max.

Focal Spot (IEC60336):

Large Focus 1.2 mm

Small Focus 0.6 mm

Input Energy (at 0.1s):

Large Focus 75 kW

Small Focus 27 kW

★The information contained herein is presented only as a guide for the applications of our products. No responsibility is assumed by TOSHIBA for any infringements of patents or other rights of the third parties which may result from its use. No license is granted by implication or otherwise under any patent or patent rights of TOSHIBA or others.

★The information contained herein may be changed without prior notice. It is therefore advisable to contact TOSHIBA before proceeding with the design of equipment incorporating this product.

Motor Ratings:

Stator: XS-AL

Duty		Starting		Running	
Power source	(Hz)	180 ⁽²⁾	60	180 ⁽²⁾	60
Input power	(W)	1100	910	83	83
Voltage	(V)	220	130	60	40
Current	(A)	5.7	7.8	1.6	2.3
Min. Speed up ⁽¹⁾	(s)	1.2	0.8	-	-
Capacitor	(µF)	6	44	6	44
Min. Braking ⁽²⁾	(s)	3 / 90 V (DC)			

Stator: XS-R

Duty		Starting		Running	
Power source	(Hz)	180 ⁽³⁾	50/60	180 ⁽³⁾	50/60
Input power	(W)	2300	1450	300	80
Voltage	(V)	460	240	130	58
Current	(A)	5.4	6.5	2.0	1.5
Min. Speed up ⁽¹⁾	(s)	1.0	0.6	-	-
Capacitor	(µF)	3	24	3	24
Min. Braking ⁽²⁾	(s)	1.5 / 90 V (DC) ⁽³⁾			

Note ⁽¹⁾ The speed up time from normal speed of 3000 min⁻¹ (3600 min⁻¹) to high speed of 10800 min⁻¹ is 2/3 times of the specified speed up time from 0 to high speed, which is described on motor rating table.

⁽²⁾ To be applied for high speed rotation.

⁽³⁾ To be obtained with AID starter Model 60/180.

Anode Speed:

50 Hz	2700 min ⁻¹ Min.
60 Hz	3200 min ⁻¹ Min.
180 Hz	9700 min ⁻¹ Min.
Resistance between Housing and Low Voltage Terminals	2 MΩ Min.

Mechanical:

Dimensions:	See dimensional outline
Overall Length	476 mm
Maximum Diameter	152.4 mm
Target:	
Angle	12 degrees
Construction	Rhenium-Tungsten-faced Molybdenum
Inherent Filtration	At least 0.7 mm Al equivalent at 75 kV
Radiation Protection (To meet the requirements of IEC 60601-1-3):	
Leakage Technique Factor	150 kV 3.4 mA
X-ray Coverage	354 × 354 mm at SID 970 mm
Weight (Approx.)	18 kg
High Tension Terminals	To meet the requirements of IEC 60526
Cooling Method	Natural or forced air
Housing (including both end plates):	
Model Number	XH-106V (X-Type)
.....	XH-180 (GX-Type)
.....	XH-181 (FX-Type)

Absolute Maximum and Minimum Ratings
(At any time, these values must not be exceeded.)

Maximum Tube Voltage:

Radiographic	150 kV
Fluoroscopic	125 kV

Maximum Voltage to Ground 78 kV

Minimum Tube Voltage 40 kV

Maximum Tube Current:

Large Focus	1000 mA
Small Focus	400 mA

Maximum Filament Current:

Large Focus	5.5 A
Small Focus	5.2 A

Filament Voltage:

Large Focus (At max. filament current 5.5 A)	12.7 ~ 17.1 V
Small Focus (At max. filament current 5.2 A)	7.0 ~ 9.4 V

Filament Frequency Limits 0 ~ 25 kHz

Average Input Power 142 W (200 HU/s)
 (Fluoroscopic, repeated radiographic or mixed exposure)

Thermal Characteristics:

Anode Heat Storage Capacity 210 kJ (300 kHU)

Maximum Anode Heat Dissipation Rate 475 W (667 HU/s)

Housing Heat Storage Capacity 900 kJ (1250 kHU)

Maximum Housing Heat Dissipation Rate:

Without Air-circulator 180 W (15 kHU/min)

Environmental Limits

Operating Limits:

Temperature 10 ~ 40 °C

Humidity 30 ~ 85 %

(No condensation)

Atmospheric Pressure 70 ~ 106 kPa

Shipping and Storage Limits:

Temperature -20 ~ 70 °C

Humidity 20 ~ 90 %

(No condensation)

Atmospheric Pressure 50 ~ 106 kPa

Warning

Warning to Interface with X-ray Generator

1. Housing Rupture

Never input over-rated power to x-ray tube assembly.

If the input power is extremely higher than specification, it may cause the over temperature of anode, insert tube glass shatter and ultimately the following serious problems due to generating over-pressure by oil vaporization inside housing assembly.

In such a critical condition, the safety thermal switch can not protect x-ray tube even if it works.

- * Housing sealing parts rupture
- * Human injury including burns due to hot oil escape
- * Fire accident due to flaming anode target

We strongly request that the x-ray generator should have a protective function which manages input power to x-ray tube assembly.

Cautions

Caution to Interface with X-ray Generator

1. Over Rating

X-ray tube assembly can be broken with applying just one over rated shot.
Please read the technical data sheets carefully and follow the instructions.

2. Inherent Filtration

The total filtration and the distance between x-ray focal spot and human body are regulated legally.
They should be complied with the regulation.

3. Safety Thermal Switch

X-ray tube assembly has safety thermal switch to prohibit further input power when the tube housing reaches to the specified temperature.

The switch should be hooked up with the x-ray generator which control output power to x-ray tube assembly.

Even if the switch works, never turn the system power off and the cooling unit should be activated.

4. Unexpected Malfunction

X-ray tube assembly may have the risk to be unexpectedly malfunctioning due to life termination or failure. If the serious problems caused by the above risk is expected, we recommend to have a contingency plan to avoid such a case.

5. New Application

If you use the product with new application not to be mentioned in this specification or with different type of x-ray generator, please contact to us for confirming its availability.

Caution for Installation, Adjustment and Maintenance

1. Qualified Persons

Only qualified persons who have technical training and professional knowledge can handle x-ray tube assembly.

2. Fragile Glass

X-ray tube is assembled with glass, therefore, it can be broken with the mechanical vibration or pulsed shock over 19.6m/s^2 (2G).

Careful handling is required to treat or transport.

3. Ground Terminal

X-ray tube assembly has ground terminal. Ground cable should be connected.

4. High Voltage

All x-ray tubes operate at voltages high enough to kill through electrical shock. Never touch the high voltage delivered plugs or terminals.

When direct access to such parts is required, the primary circuit should be disabled and high voltage capacitors/cables discharged.

5. High Voltage Plug

High voltage plug should be cleaned up and free from any physical damages. Silicon compound application is required for high voltage stability.

6. Operation Atmosphere

X-ray tube assembly is not allowed to use in the atmosphere of flammable or corrosive gas.

7. Protective Cover

X-ray tube assembly is not allowed to use without the protective cover attached.

8. Handling

Appropriate jig or tools are required for tube installation to avoid physical damages.

9. Returning Tube

X-ray tube assembly should be repackaged with the original material when it is returned back for quality examination in our factory.

Be careful to put the tube upside cathode. If the packaging is not proper, the tube may not be correctly examined.

Caution in Operation

1. X-Ray Radiation

X-ray tube assembly should have the beam limiting equipment mounted on the x-ray port to protect unnecessary radiation.

2. Dielectric Oil

X-ray tube assembly has dielectric oil contained for high voltage stability. As it is poisonous for human health, if it is exposed to the non-restricted area, it should be disposed as following to the local regulation.

3. Operation Atmosphere

X-ray tube assembly is not allowed to use in the atmosphere of flammable or corrosive gas.

4. Lead Disposition

X-ray tube housing is lined with lead to protect unnecessary radiation. As the lead powder or vapor is harmful for human health, it should be disposed as following to the local regulation or returned back to us with your cost of transportation. We dispose it in our facility with free of charge.

5. Safety Thermal Switch

X-ray tube has thermal switch to protect over heat on housing. As the housing temperature goes up to maximum 85°C, never touch on housing surface in operation.

6. Any Malfunction

Please contact to your system service person immediately, if any malfunction is noticed.

Caution Label

- (a) This label is a caution label to notify the user of the following point.
"Housing end cap is used to protect the electric shock and x-ray leakage."

Attachment position : X-ray tube assembly housing end cap



Maximum Rating Charts

(Absolute Maximum Rating Charts)

Conditions : Tube Voltage Three-Phase

Stator Power Frequency 180Hz

Focal Spot : 1.2 mm

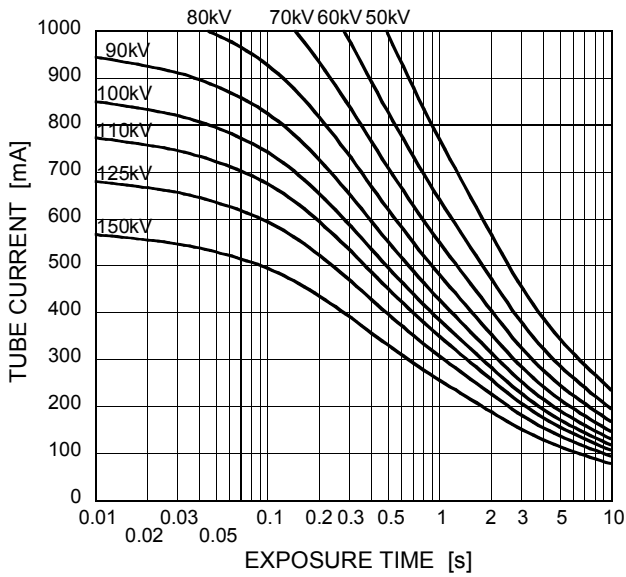

Focal Spot : 0.6 mm

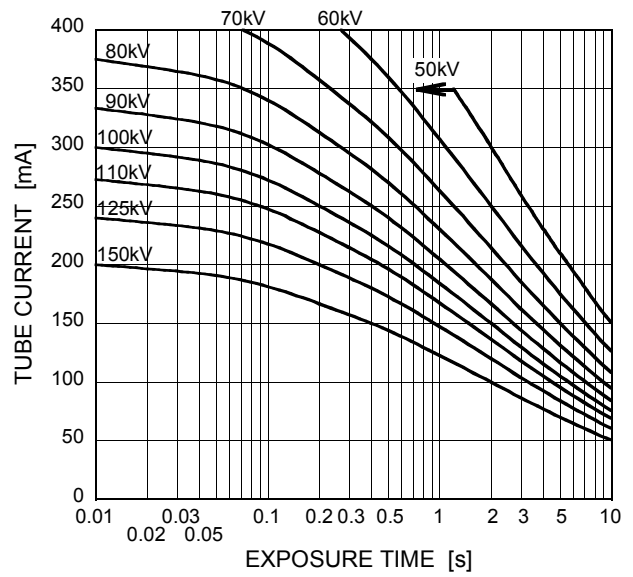

Conditions : Tube Voltage Single-Phase

Stator Power Frequency 180Hz

Focal Spot : 1.2 mm

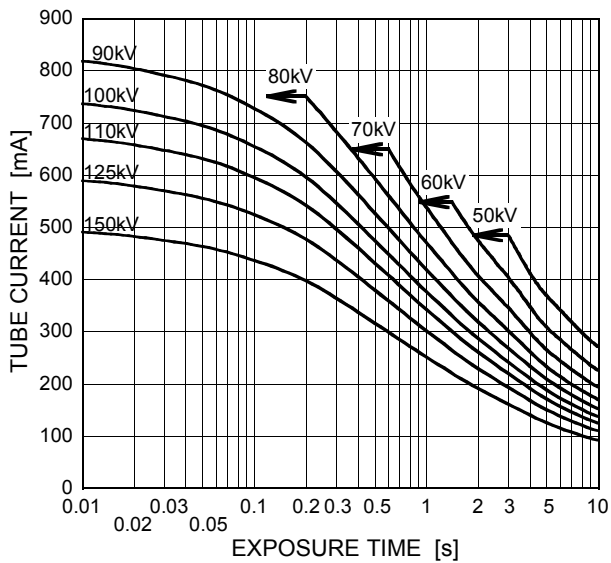

Focal Spot : 0.6 mm

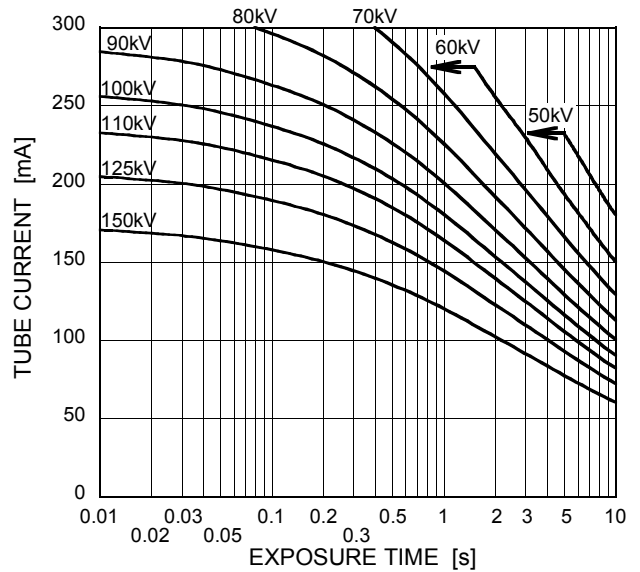

Maximum Rating Charts

(Absolute Maximum Rating Charts)

Conditions : Tube Voltage Three-Phase

Stator Power Frequency 60Hz

Focal Spot : 1.2 mm

Focal Spot : 0.6 mm

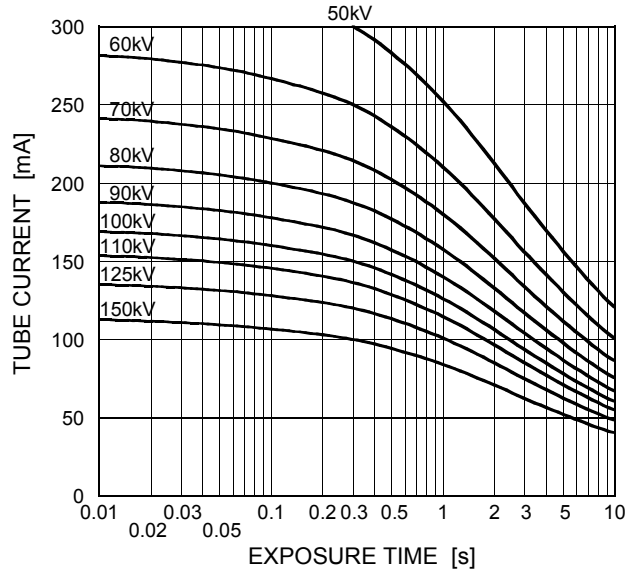
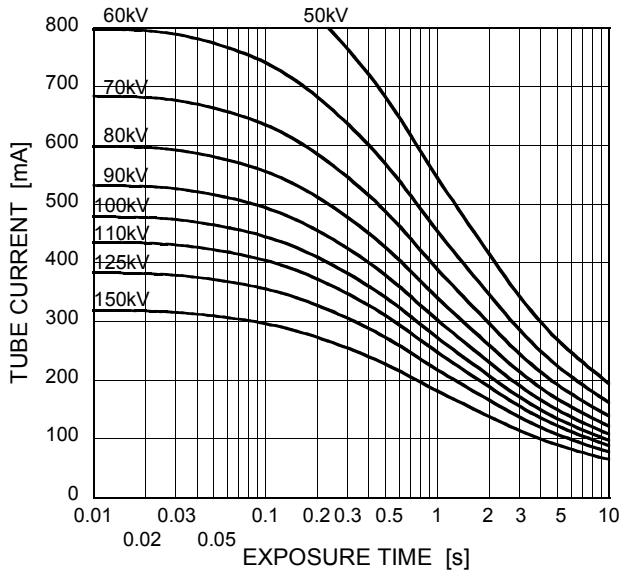

Conditions : Tube Voltage Single-Phase

Stator Power Frequency 60Hz

Focal Spot : 1.2 mm

Focal Spot : 0.6 mm

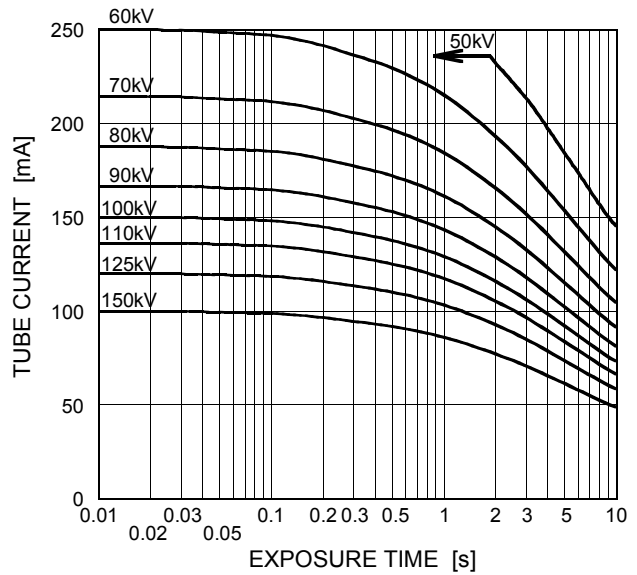
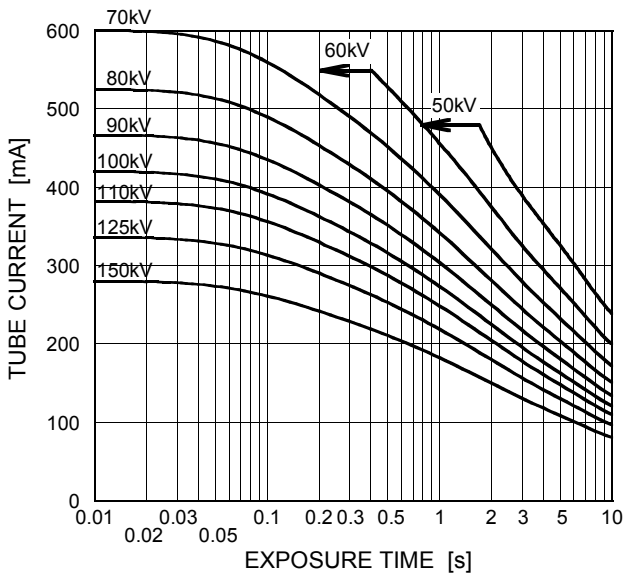

Emission & Filament Characteristics

Three-Phase

Focal Spot : 1.2 mm

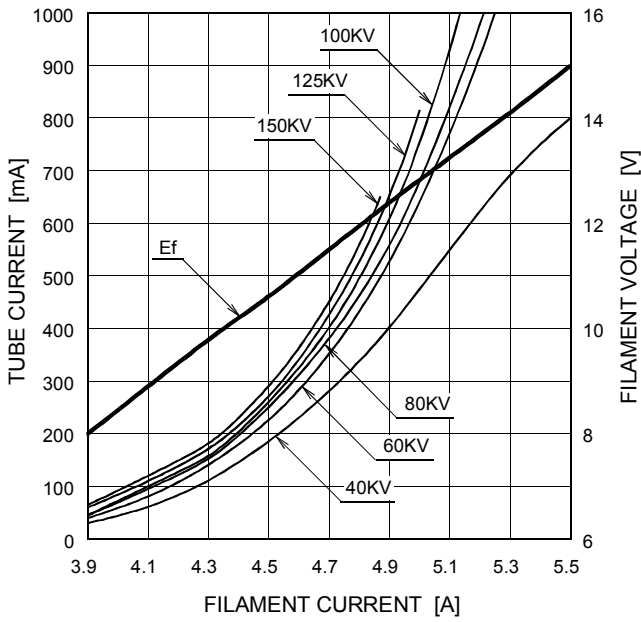

Focal Spot : 0.6 mm

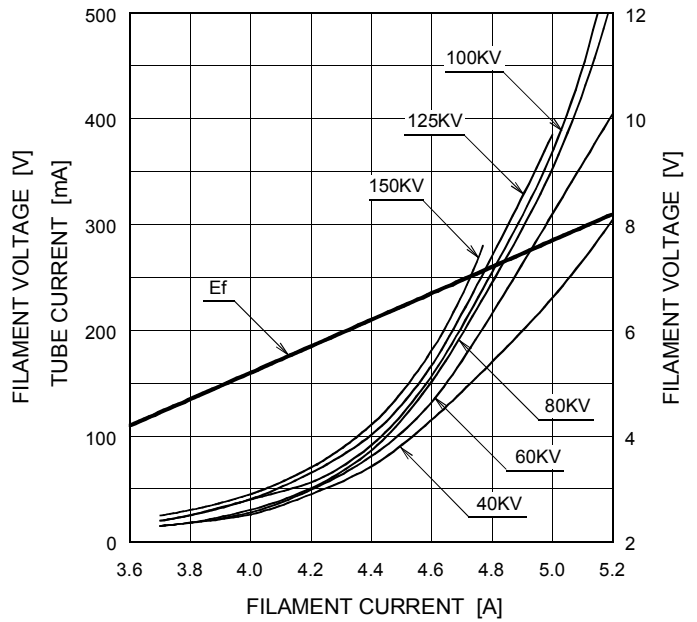

Single-Phase

Focal Spot : 1.2 mm

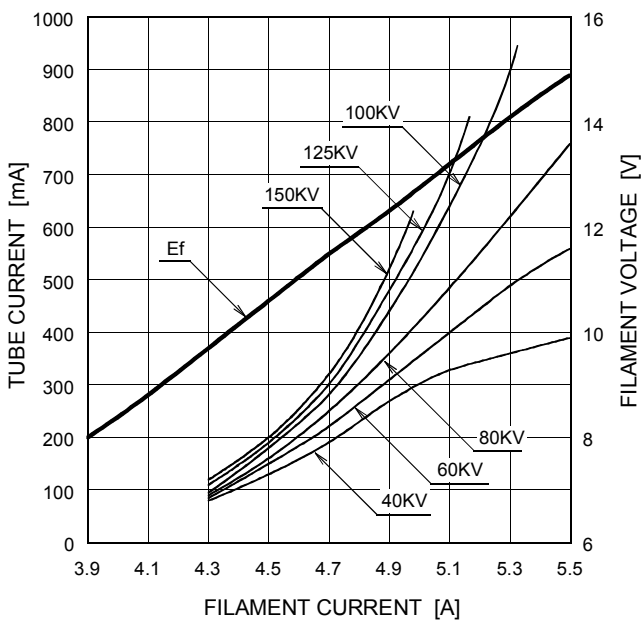

Focal Spot : 0.6 mm

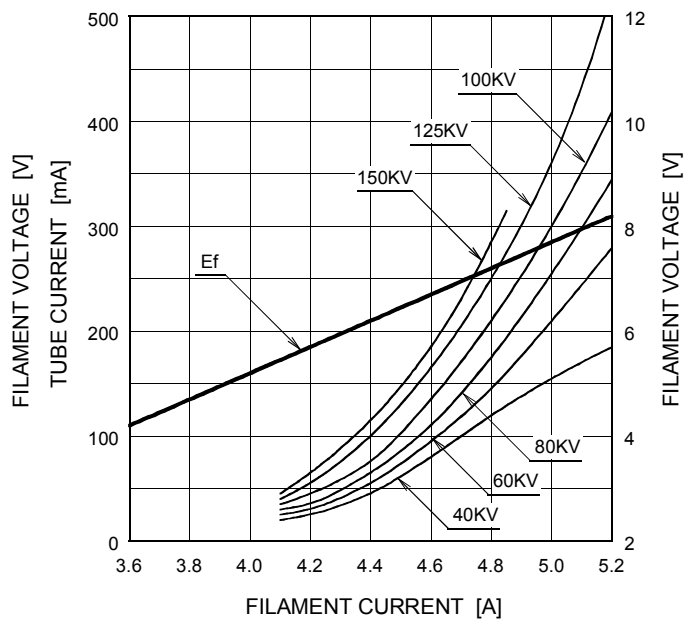

Thermal Characteristics

Housing Thermal Characteristics

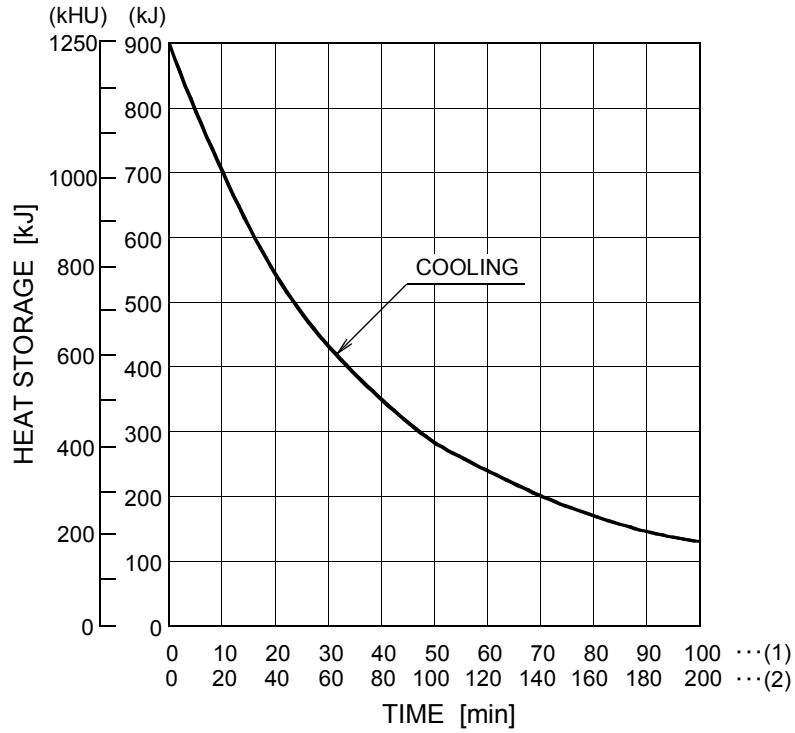

- (1) Cooling with Air Circulator.
- (2) Cooling Without Air Circulator.

Anode Thermal Characteristics

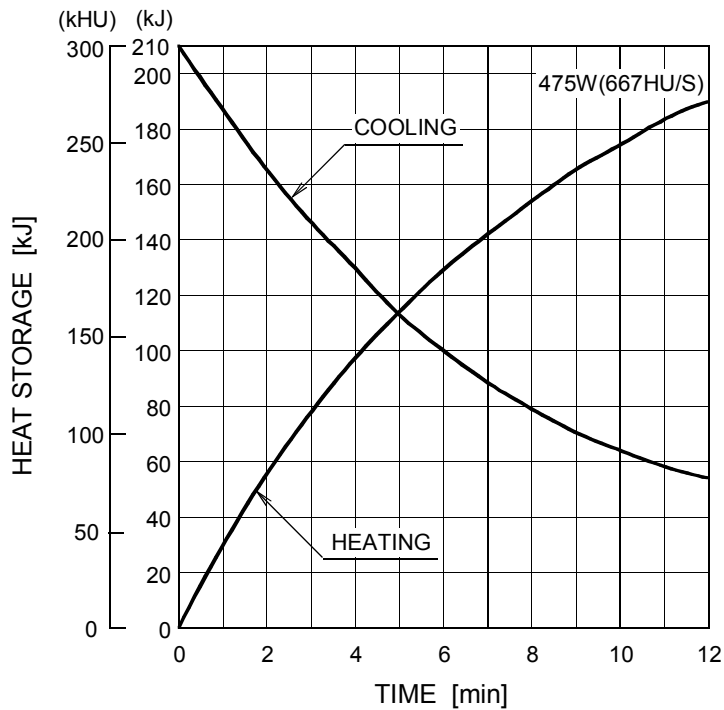

The heating curves are showing examples of average input power to the anode in operation.

Dimensional Outline of E7252FX

Unit mm

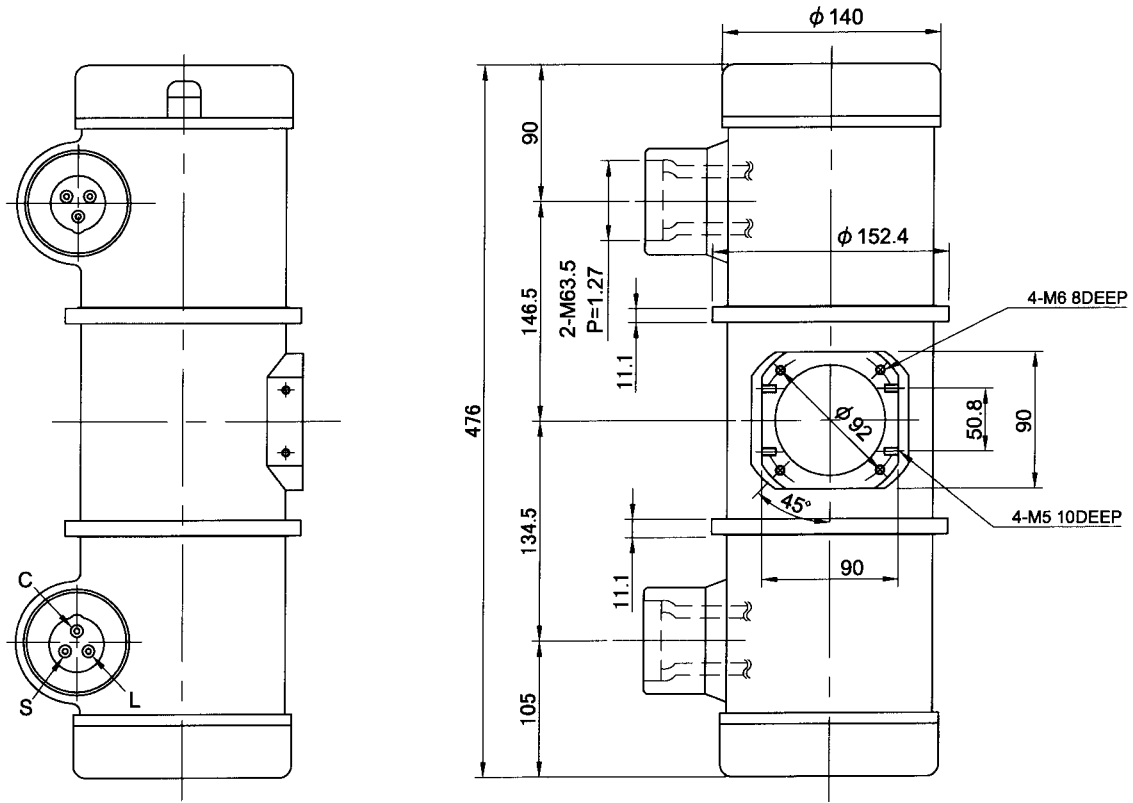

TERMINAL CONNECTIONS

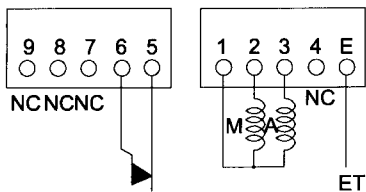

Note) Do not connect terminal No.1 and No.5 or 6 in series circuit.

- C : COMMON
- L : LARGE FOCUS
- S : SMALL FOCUS
- M : MAIN WINDING OF THE STATOR
- A : AUX. WINDING OF THE STATOR
- NC : NON-CONNECTION
- ET : EARTH TERMINAL
- ST : SHIELD TERMINAL (at cable clamp)
- ▲ : CENTRAL X-RAY ANODE & CATHODE TERMINAL
- : IEC 60526 TYPE

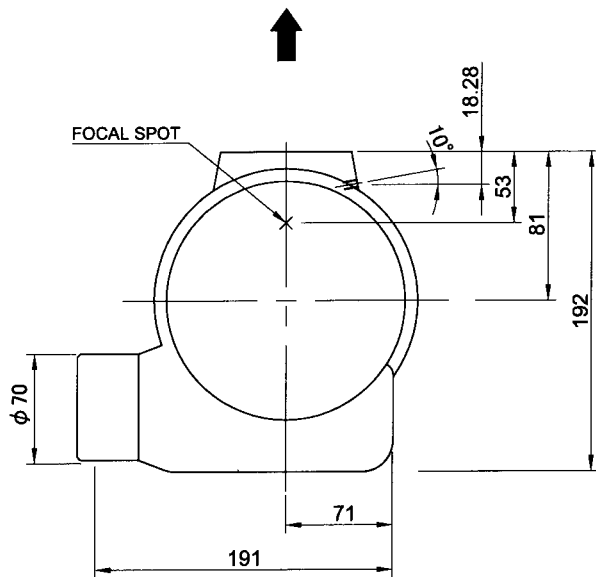

Dimensional Outline of E7252GX

Unit mm

TERMINAL CONNECTIONS

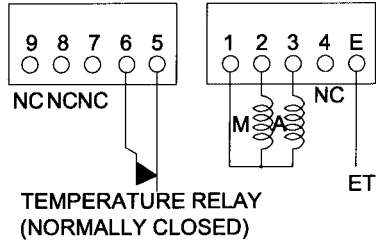

Note) Do not connect terminal No.1 and No.5 or 6 in series circuit.

- C : COMMON
- L : LARGE FOCUS
- S : SMALL FOCUS
- M : MAIN WINDING OF THE STATOR
- A : AUX. WINDING OF THE STATOR
- NC: NON-CONNECTION
- ET: EARTH TERMINAL
- ST: SHIELD TERMINAL (at cable clamp)
- ▲ : CENTRAL X-RAY
- ANODE & CATHODE TERMINAL
: IEC 60526 TYPE

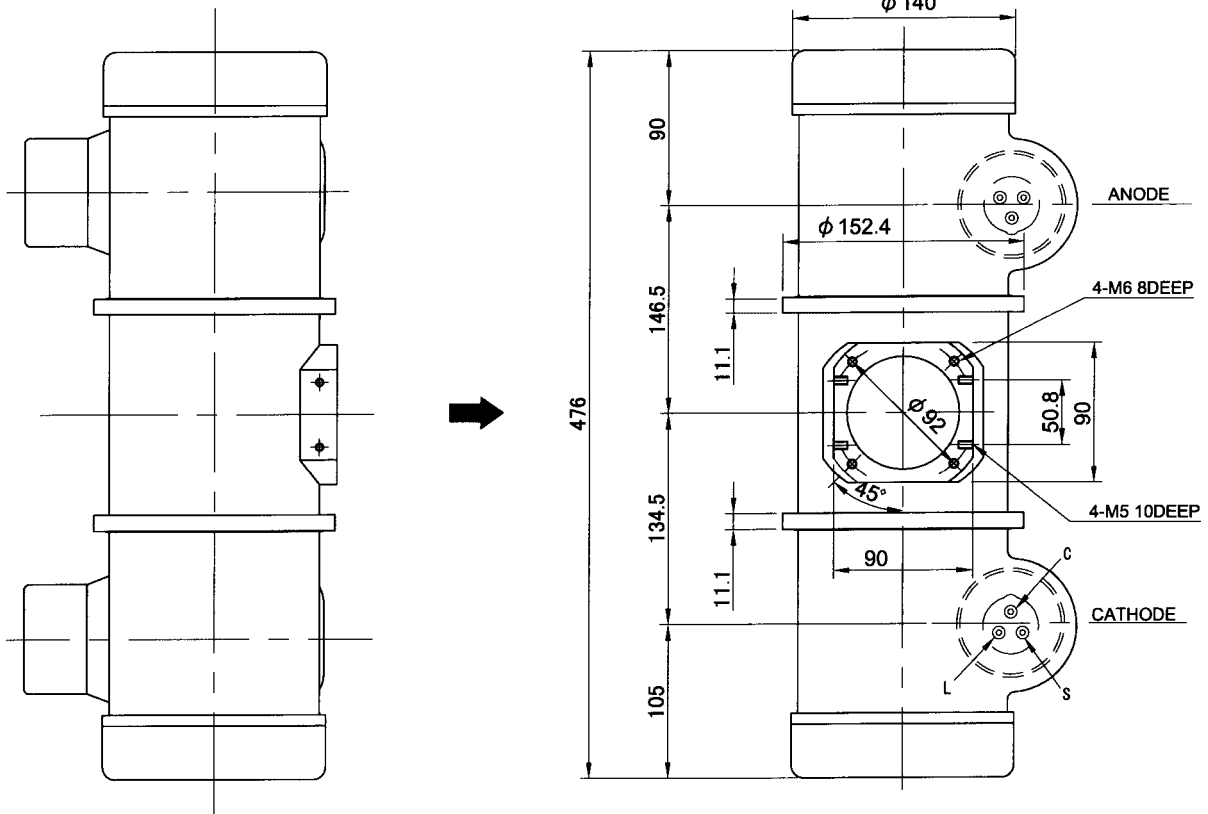
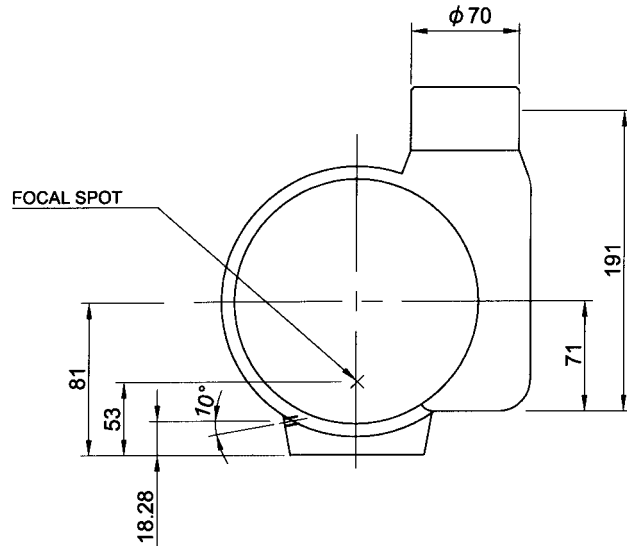

Overseas Subsidiaries and Affiliates

- **Toshiba America Electronic Components, Inc.**
One Parkway North, Suite 500, Deerfield, IL 60015-2547, USA
Phone (847) 945-1500 Fax (847) 945-1044

- **Toshiba Electronics Europe**
Riverside Way, Camberley, Surrey. GU15 3YA U.K.
Phone +44 (0) 1276 694600 Fax +44 (0) 1276 694800

